

WICHTIG - FÜR SPÄTERE VERWENDUNG
AUFBEWAHREN - SORGFÄLTIG LESEN

AVIS - Ces instructions doivent être sauvegardées
Pour utilisation future - Les instructions doivent
être suivies

IMPORTANTE, conservar estas instrucciones
para futuro uso. Siga estas instrucciones atentamente

VIGTIGT - Samvejledningen skal opbevares
i arkiv til senere brug - Skal gennemlæses nøje

NOTICE - These instructions must be saved
for future use - Instructions must be followed

TEILCHECKLISTE
 LISTE DE CONTROLE
 LISTADO DE CONTROL
 TJEKLISTE
 CHECK LIST

Réf. /No.	Réf. /Art.	Qty. /Stck. /Quantité	Size / Maß / Dimension (mm)	Qty. /Stck. /Quantité	
1	56XXXX0026101	1	950X480X132		✓
2	56XXXX0026102	1	470X624X20		
3	56XXXX0026103	1	470X624X20		
4	56XXXX0026104	1	904X20X20		
5	56XXXX0026105	1	904X20X20		
6	56XXXX0026106	1	936		

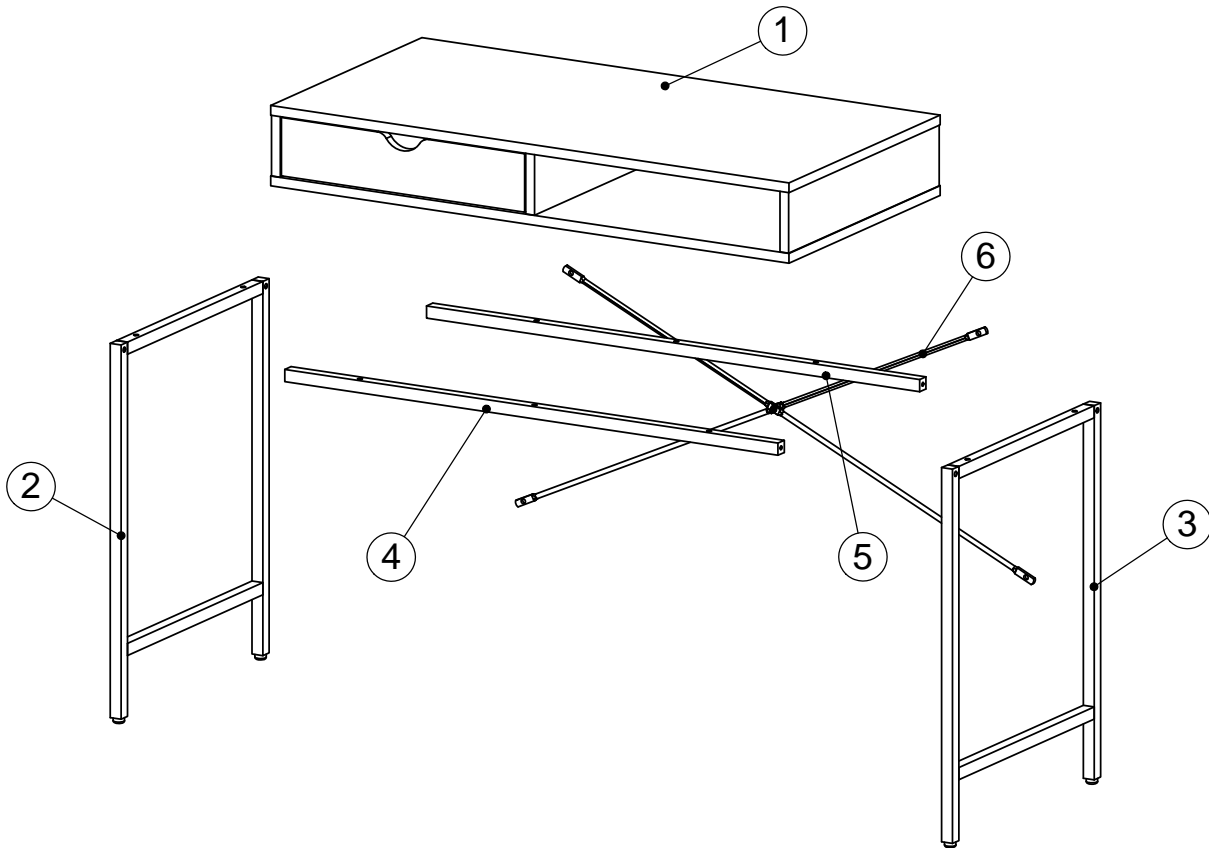

Sollten Sie eventuelle Ersatzteile oder Reklamationsteile fordern, dann bitten wir Sie, diese Seite mitzubringen.

En cas de service apres - vente,veuillez nous retourner ce coupon.

En caso de necesitar piezas de repuesto, por favor adjunte esta página.

Skulle de få brug for reklamationsdele, beder vi dem medsende denne side.

If you should be in the need of spareparts, please enclose this page.

Name/Nom/Nombre/Navn: _____

Adresse/Dirección/Address: _____

PLZ/Code postale/CP/Post.nr: _____

Telefon/Telephone/Telefono/Phone: _____

Oberfläche/Finition/Tratamiento/ Behandlung/Treatment: _____



No./Référence: _____

Ursache/Motif/Motivo/Årsag/Reason: _____

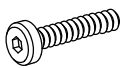
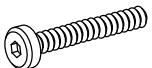
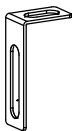
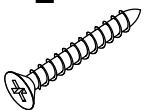

TEILCHECKLISTE - LISTE DE CONTROLE - LISTADO DE CONTROL- TJEKLISTE - CHECK LIST

Réf./No.	Réf./Art.	Qty./Stck./Quantité	
A	983204	4	
B	983069	10	
C	982036	4	
D	982550	2	
E	982552	2	
F	982554	4	
G	69004	1	

<p>4 - A</p>  <p>M6x12mm (M6 x 1/2")</p>	<p>10 - B</p>  <p>M6x30mm (M6 x 1 3/16")</p>	<p>4 - C</p>  <p>M6x50mm (M6 x 1 9/16")</p>	<p>2 - D</p>  <p>60x30x19mm</p>	<p>2 - E</p>  <p>Ø 4.0x50mm</p>	<p>4 - F</p>  <p>Ø 16mm</p>
<p>1 - G</p>  <p>M4mm (1/8")</p>					

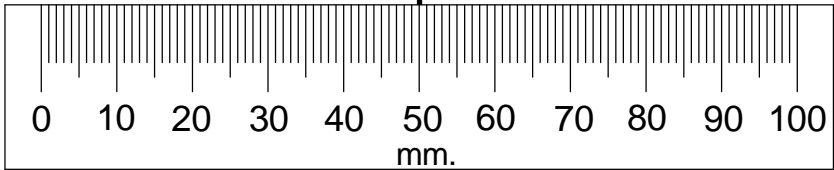
<p>Geehrter Kunde. Hier haben Sie die Möglichkeit die mitgelieferten Schrauben nachzumessen.</p> <p>Cher Client. La règle ci jointe vous permet de mesurer la visserie.</p> <p>Estimado cliente. aquí podrá medir la tornillería adjunta.</p> <p>Kære kunde. Her har De muligheden for at måle medsendte beslag.</p> <p>Dear Customer. Below you have the opportunity to measure the Enclosed Hardware.</p>	<p>Name/Nom/Nombre/Navn: _____</p> <p>Adresse/Dirección/Address: _____</p> <p>PLZ/Code postale/CP/Post.nr: _____</p> <p>Telefon/Telephone/Telefono/Phone: _____</p> <p>Oberfläche/Finition/Tratamiento/ Behandling/Treatment: _____</p> <p>No./Réfrence: _____</p> <p>Ursache/Motif/Motivo/Årsag/Reason: _____</p>
	



1 4 - C 1 - G

B ~~M6X30~~

C M6X50

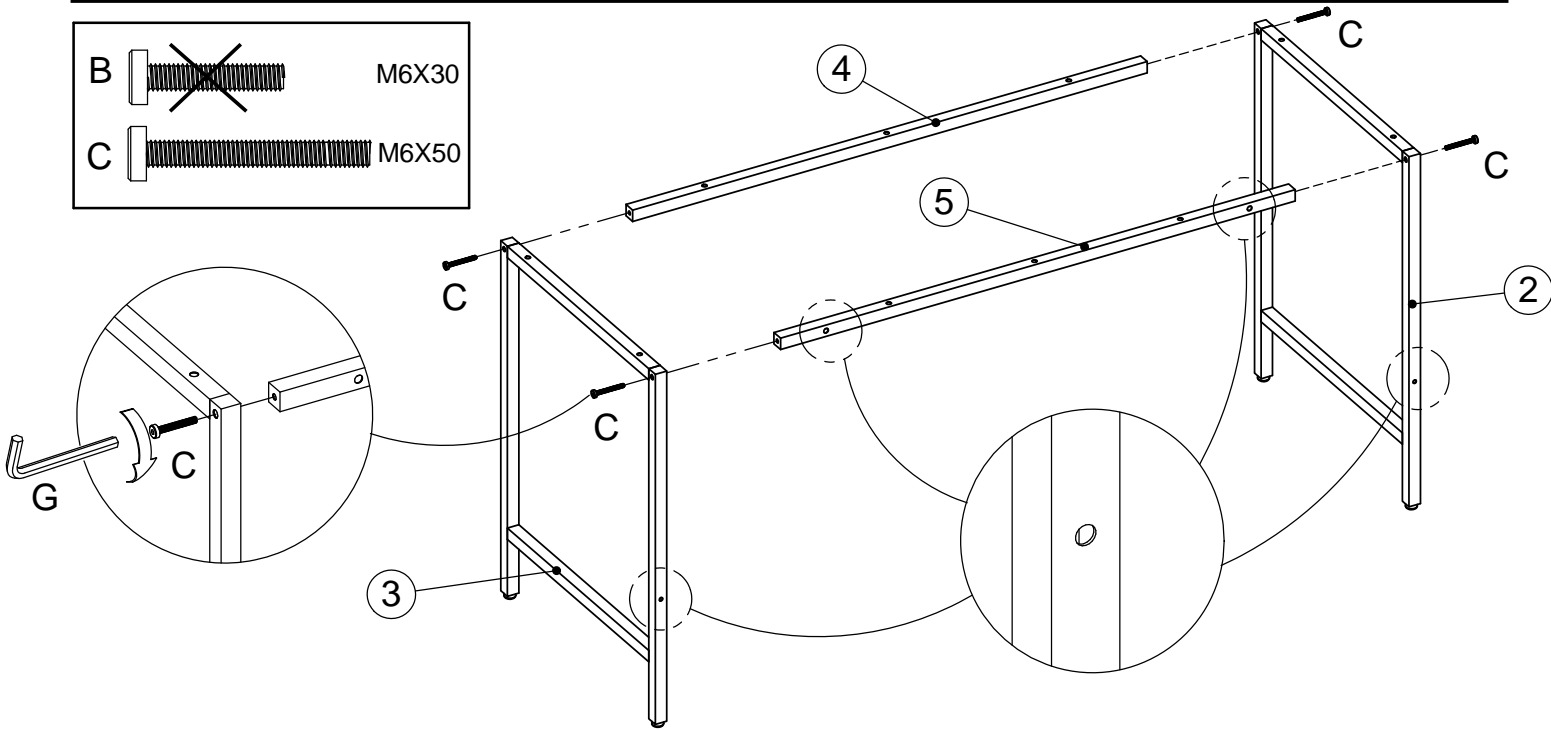

2 4 - A 1 - G

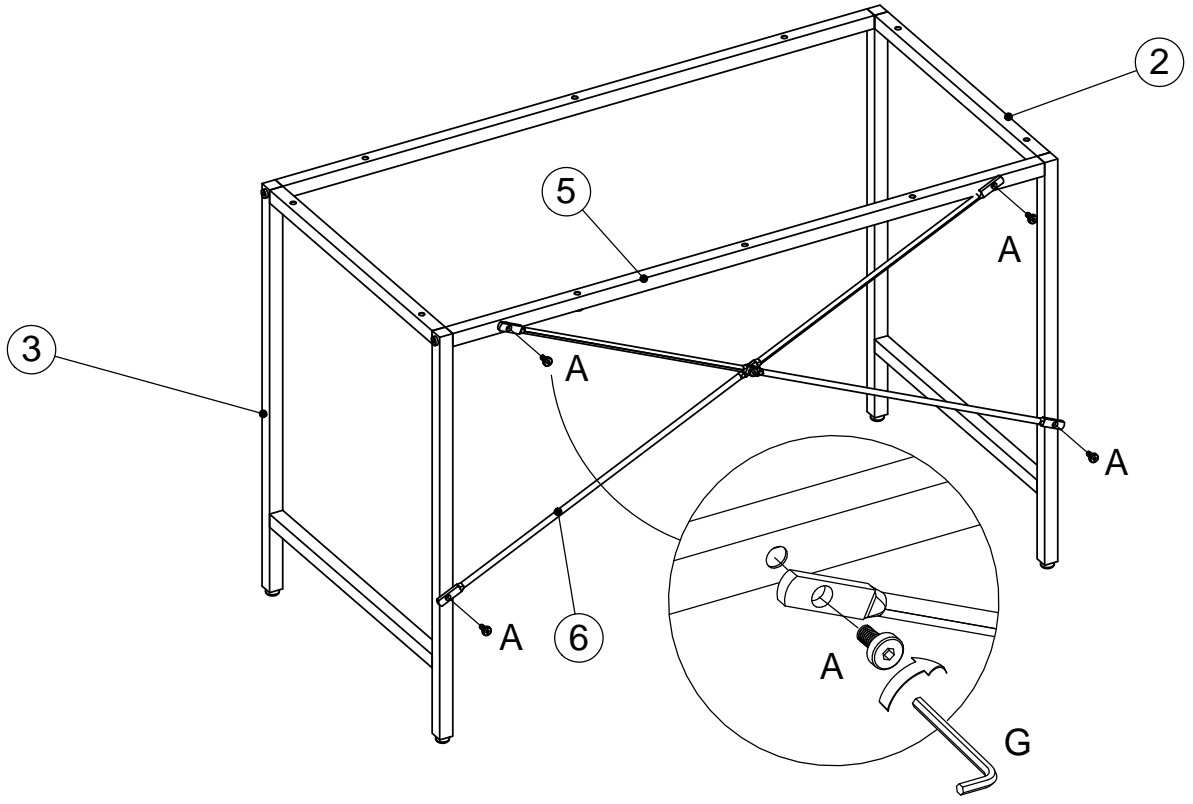

3
 10 - B 2 - D 2 - E 1 - G

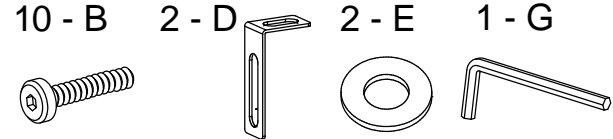
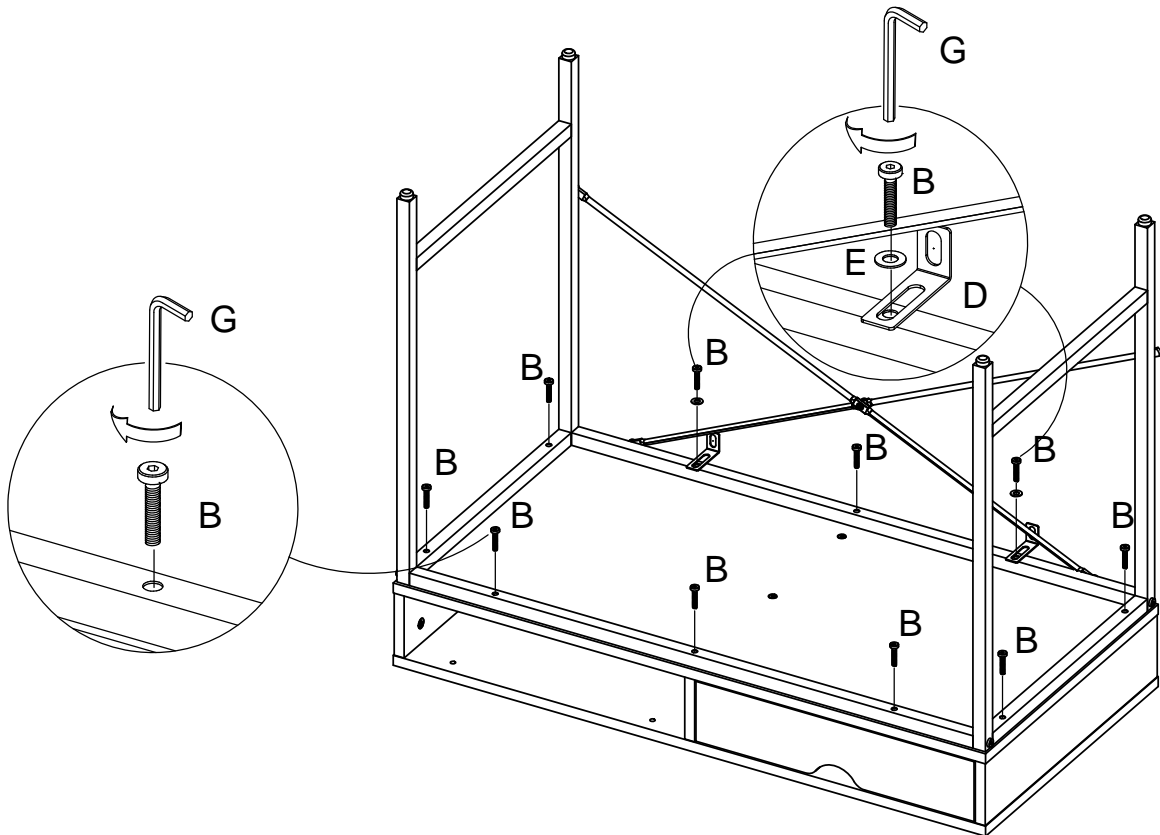
4

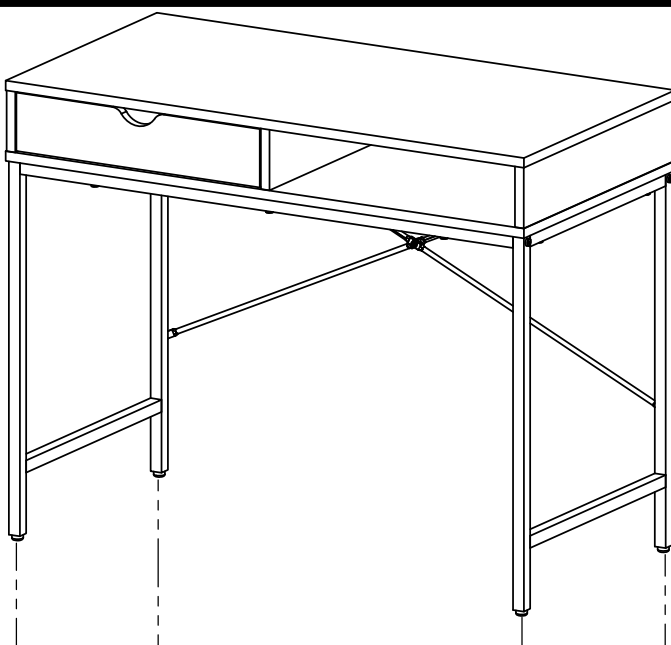

5 - 7

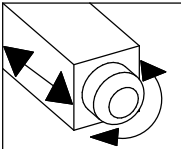

5

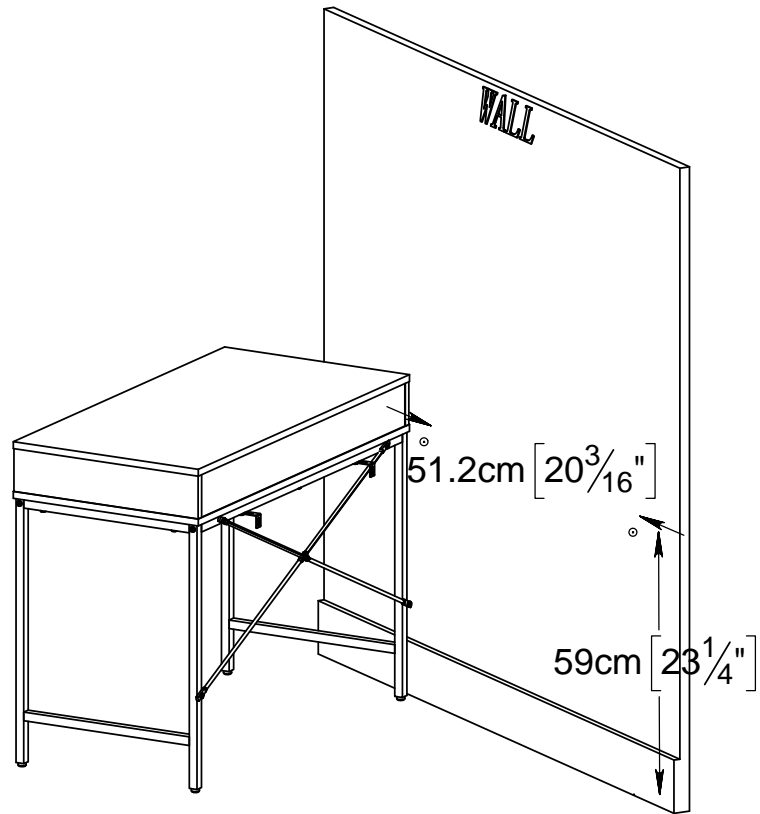

6

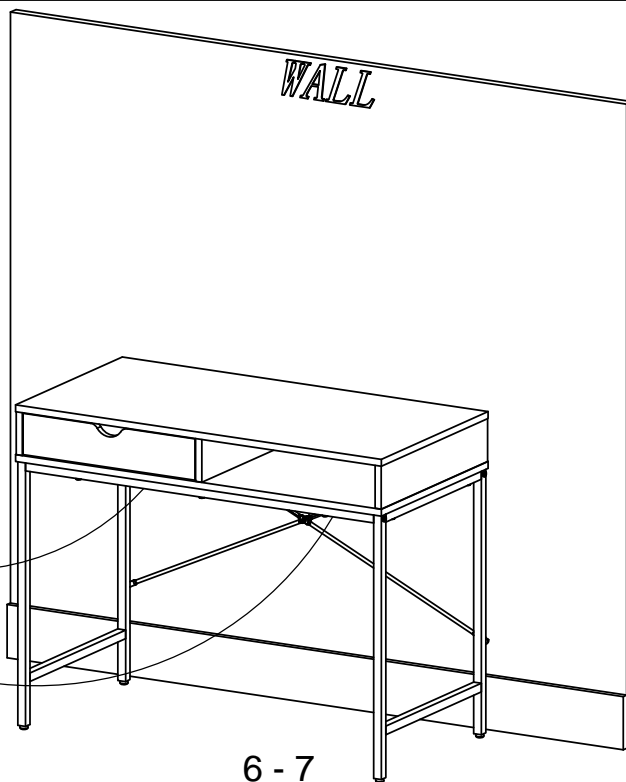
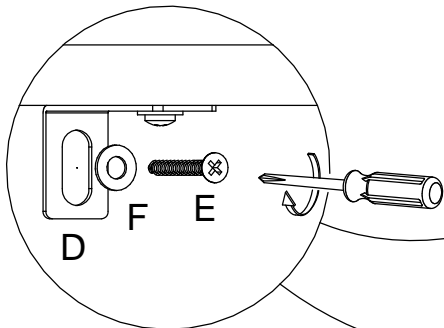
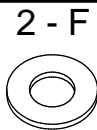
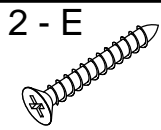

6 - 7

7

OPTIONAL: DRAWER ON RIGHT SIDE

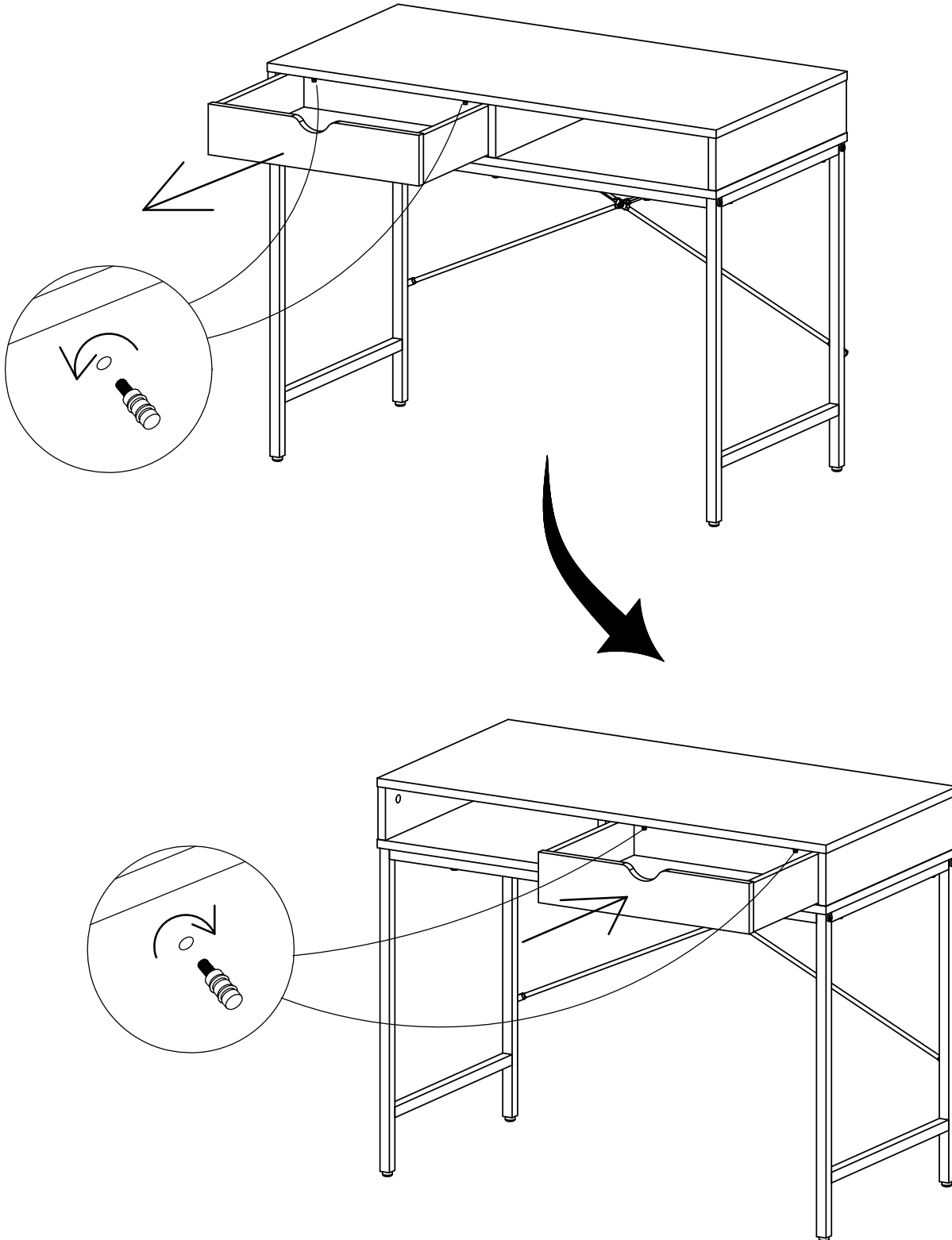



UK / US:

There are many different types of walls and partitions. We are therefore not able to enclose the correct screws and wall plugs. Before purchasing the appropriate wall plugs and screws, it is essential to find out which type of wall/partition the product needs to be fastened to. Here are some examples of recommended wall plugs/screws for:

DE:

Es gibt viele verschiedene Wand- und Abtrennungsarten. Daher ist es uns nicht möglich, die korrekten Schrauben und Dübel mitzuliefern. Bevor Sie die entsprechenden Dübel und Schrauben kaufen, ist es nötig, festzustellen, an welcher Art von Wand/Abtrennung das Produkt befestigt wird. Hier finden Sie einige Beispiele für empfohlene Dübel/Schrauben für:

FR / CAN:

Il y a beaucoup de types de murs et de cloisons différents. Nous ne sommes donc pas en mesure de joindre les vis et chevilles appropriées. Avant d'acheter les chevilles et les vis appropriées, il est essentiel de savoir quel type de mur/cloison du produit doit être fixé. Voici quelques exemples de chevilles/vis recommandées pour:

ITA:

Esistono molte tipologie di pareti e divisori. Non siamo pertanto in grado di allegare tutti i corrispettivi perni e viti di fissaggio. Prima dell'acquisto delle viti o dei perni più appropriati, è necessario individuare il tipo di parete/divisorio a cui il prodotto deve essere fissato. Forniamo di seguito alcuni esempi di perni/viti raccomandati per:

ES:

Existe una variedad infinita de paredes y tabiques. Por tanto nosotros no somos capaces de incluir los tornillos y tacos de pared apropiados. Antes de comprar los tacos y tornillos de pared correctos, es esencial saber el tipo de pared/tabique al que hay que fijar el producto. He aquí algunos ejemplos de los tacos/tornillos de pared recomendados para:

CAT:

Hi ha diferents menes de parets i envans. Per aquest motiu no podem incloure els cargols i els tacs adequats per a totes les parets. Abans de comprar els cargols i els tacs adequats, cal esbrinar a quina mena de paret o envà anirà muntat el producte. Aquí teniu alguns exemples de cargols i tacs recomanats per a:

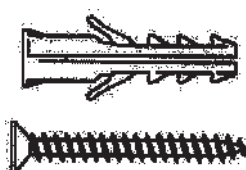
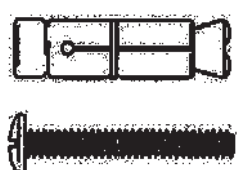
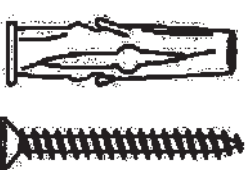
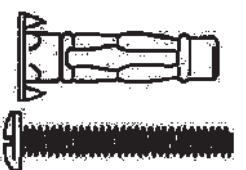
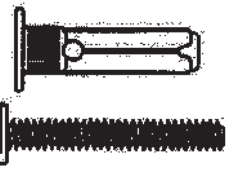
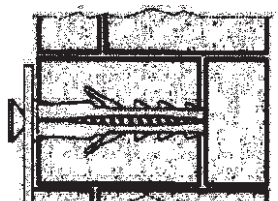
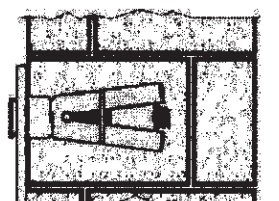
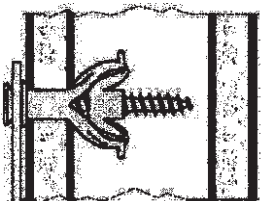
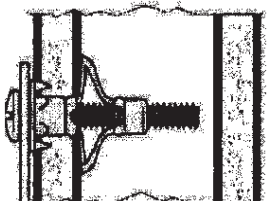
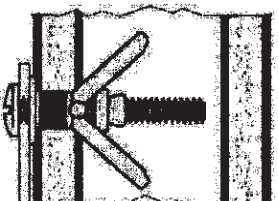
UK / US: Brick Walls DE: Ziegelwände FR / CAN: Murs de briques ITA: Pareti di mattoni ES: Paredes de ladrillo CAT: Parets de totxo				
<p>UK / US: Nylon Plug "Fischer" DE: Nylon-Dübel "Fischer" FR / CAN: Cheville en nylon à expansion "Fischer" ITA: Prese "Fischer" in nylon ES: Taco de Nylon "Fischer" CAT: Tac de niló "Fischer"</p> 	<p>Metal expansion bolt Metall-Dehnschraube Boulon à expansion en métal Perni ad espansione in metallo Taco metálico expansible Cargol d'expansió metàl·lic</p> 	<p>Nylon expansion bolt Nylon-Dehnschraube Boulon à expansion en nylon Perni ad espansione in nylon Taco expansible de nylon Cargol d'expansió de niló</p> 	<p>Cavity anchor Hohlräumdübel Cheville de verrouillage Cavità di ancoraggio Anciaje de pared hueca Ancoratge per a cavitats</p> 	<p>Cavity anchor "Molly" Hohlräumdübel "Molly" Cheville de verrouillage de forme "Molly" Cavità di ancoraggio "Molly" Anciaje de pared hueca "Molly" Ancoratge per a cavitats de tipus "Molly"</p> 
				



UK / US: Use a drill suitable for the type of wall and the chosen wall plug.

DE: Verwenden Sie einen für die Wand und die gewählte Dübelart passenden Bohrer.

FR / CAN: Utiliser une perceuse appropriée pour le type de mur et la prise murale choisie.

ITA: Utilizzare un trapano adatto al tipo di parete e al tipo di perno selezionato.

ES: Utilice una máquina taladradora adecuada para el tipo de pared y el taco preferido.

CAT: Cal fer servir una broca adequada per al tipus de paret i el tac escollit.