

ASSEMBLY INSTRUCTIONS



DANISH DESIGN

Thank you for purchasing Jesper products! We trust you will be satisfied with it for many years to come. Before you discard the packing material and start assembly, please take time to identify all hardware and parts needed for completion. As you unpack, please place all parts on a clean carpeted or padded area to avoid accidental damage.

HARDWARE		MODEL NO.	
		381/382	
983400	M8	Length= $4\frac{4}{5}$ " Packed with legs a x 8	690003 i x 1
983401	M6	Length= $1\frac{2}{5}$ " Packed with legs b x 4	983410 j x 4
983406	M6	Length= $3\frac{3}{5}$ " c x 4	983411 M6 Length= $3\frac{3}{5}$ " k x 28
983407	M6	Length= $1\frac{1}{2}$ " d x 4	982741 l x 2
983408	e x 2		m x 1
983409	f x 2		n x 2
983791	g x 1		982742 o x 1
983423	M6	Length= $4\frac{4}{5}$ " h x 1	983415 p x 1
			982724 M6 Packed with legs q x 1
			982723 M4 r x 1

PARTS LIST AND INSTRUCTIONS

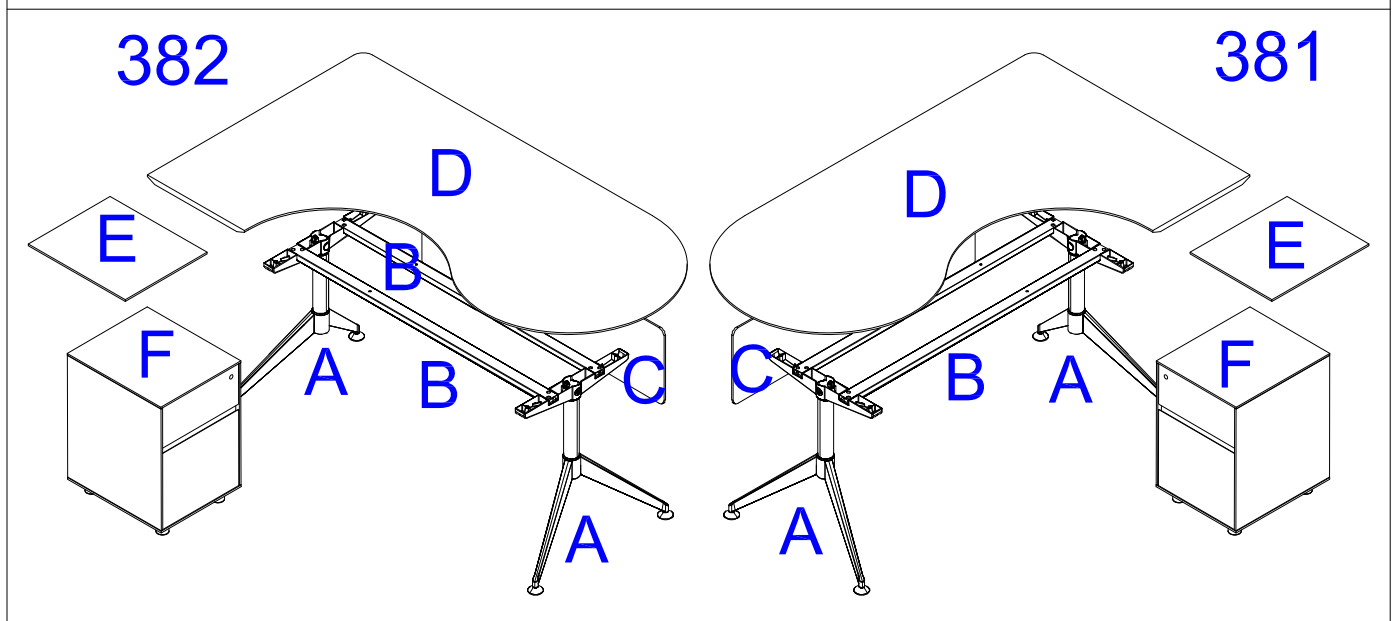

Maintenance!

Melamine & Lacquer surfaces: Clean using a mild non detergent soap solution and wipe off excess with a dry soft cloth. Avoid placing sharp items directly on surface.

Aluminum and other metal parts: Clean using a mild non detergent soap solution and wipe off with a clean damp cloth. Use rubbing alcohol for stubborn stains.

Never use solvents for cleaning furniture.

Location: Avoid placing furniture in moist areas or in direct sunlight.

Should you need any other information, please contact the retail store where you purchased the products or Jesper Office Inc.

info@jesperoffice.com

Phone 908-218-4200 Fax 800-JESPER-2

1

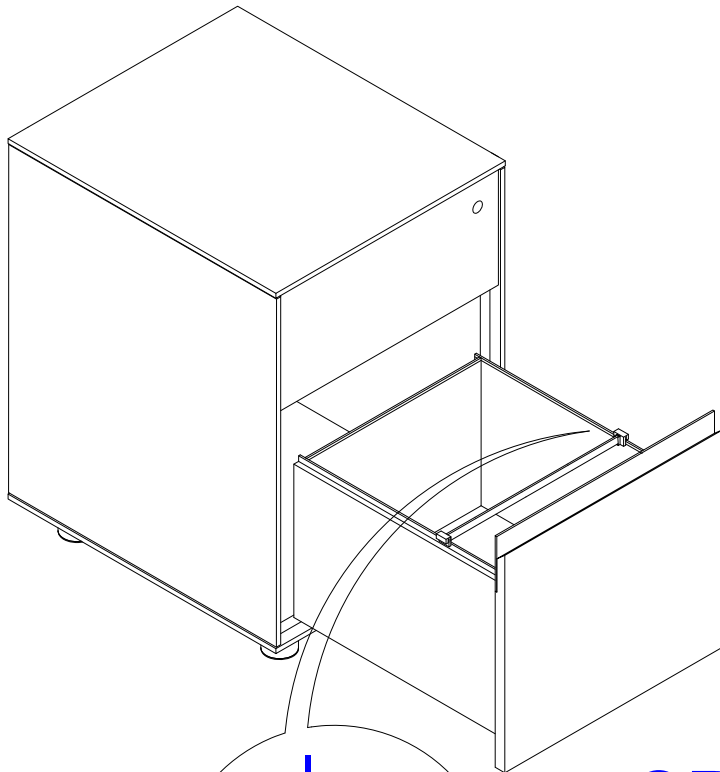
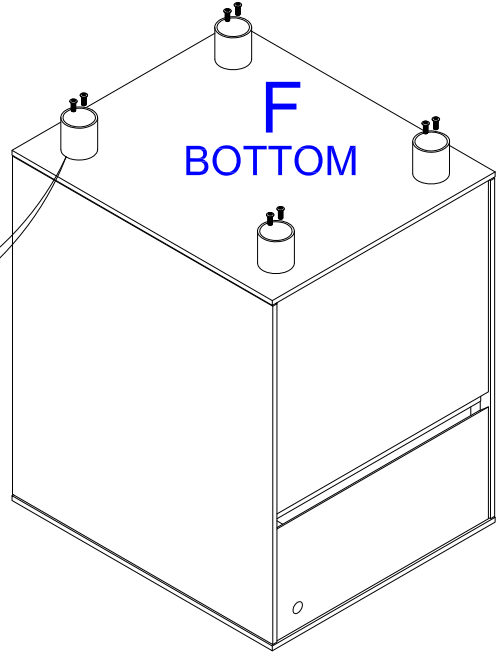
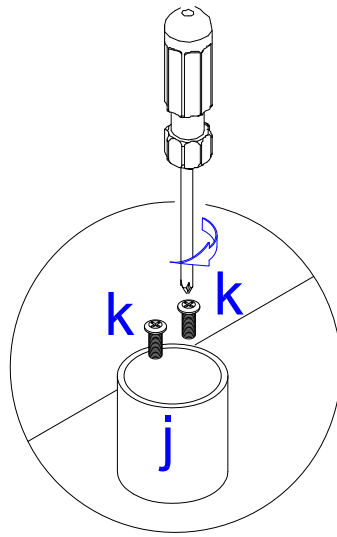

2

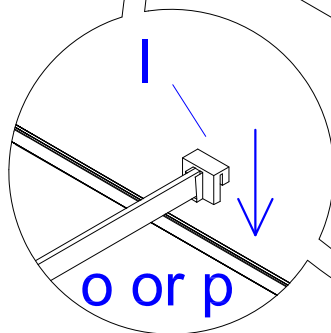

OR

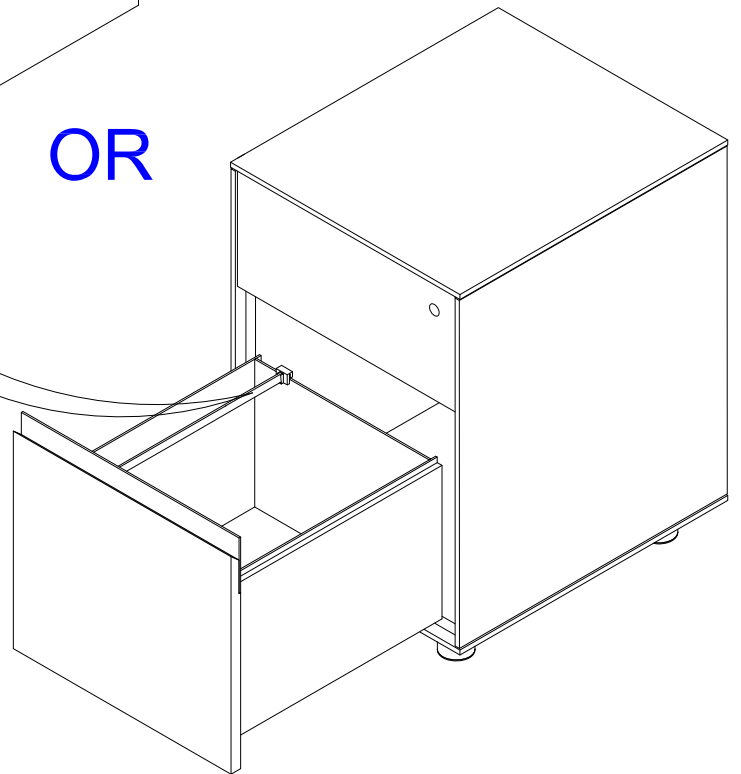

3

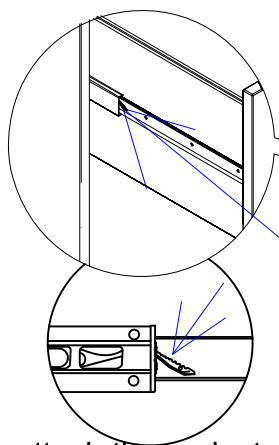

To attach the pedestal to the top, you must first remove the top drawer. This is done by pushing down the shown plastic pin on the right side and pulling it up on the left side of the file drawer, simultaneously, then pull the drawer out.

4

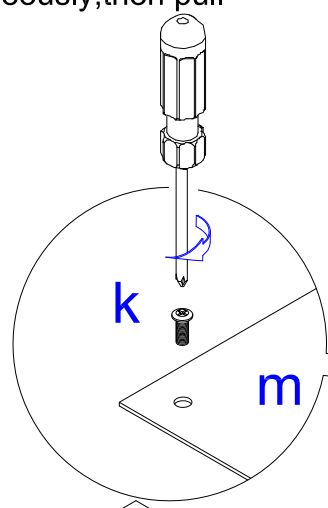
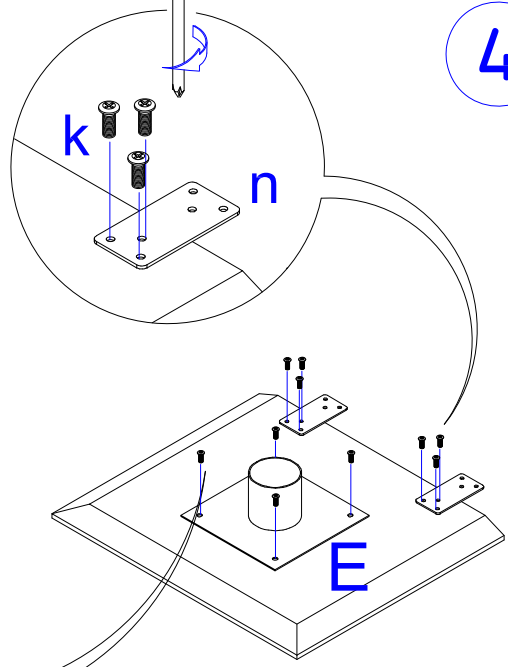

5

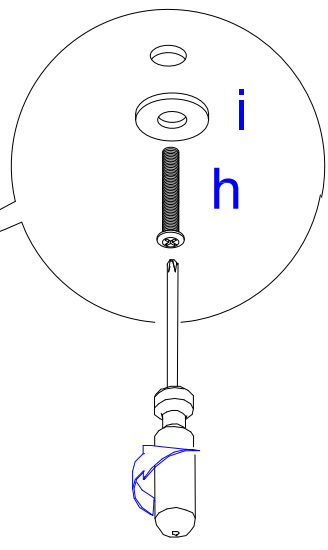
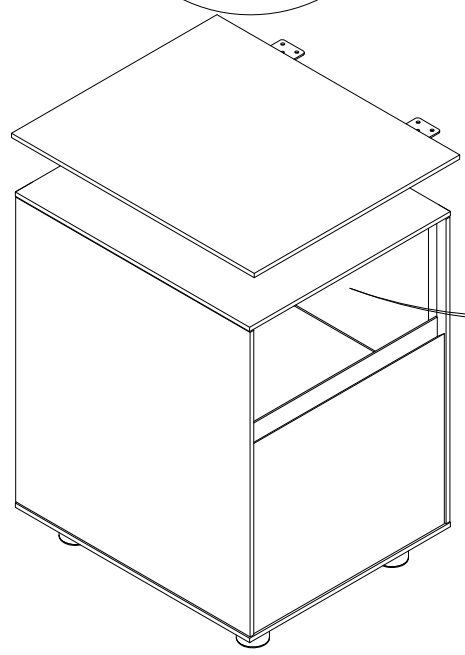

6

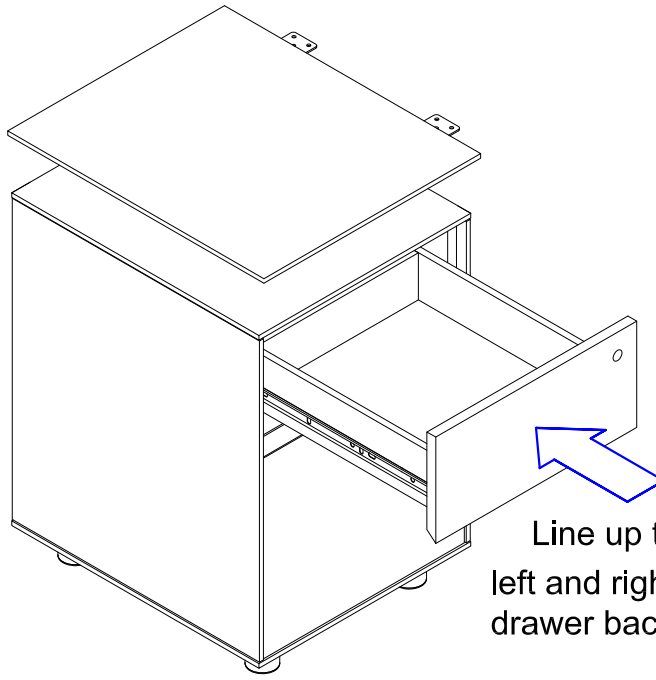

Line up the drawer glides
left and right, then slide the
drawer back in.

7

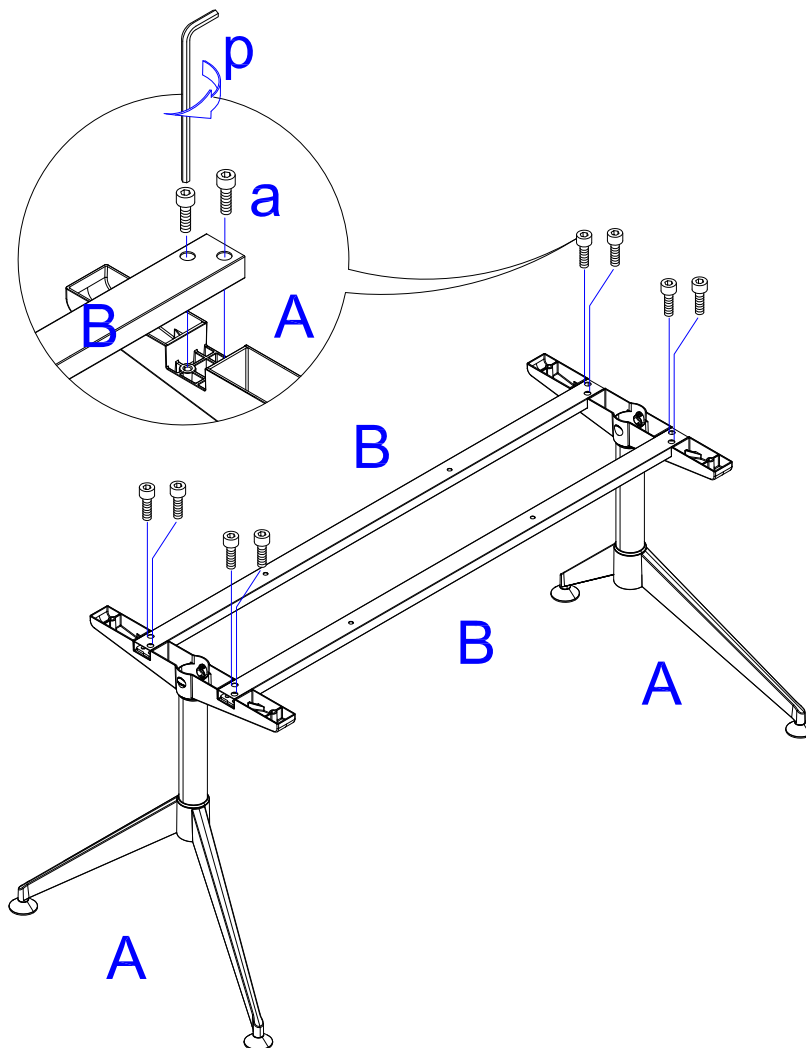

Right side facing cabinet
381

Left side facing cabinet
382

8

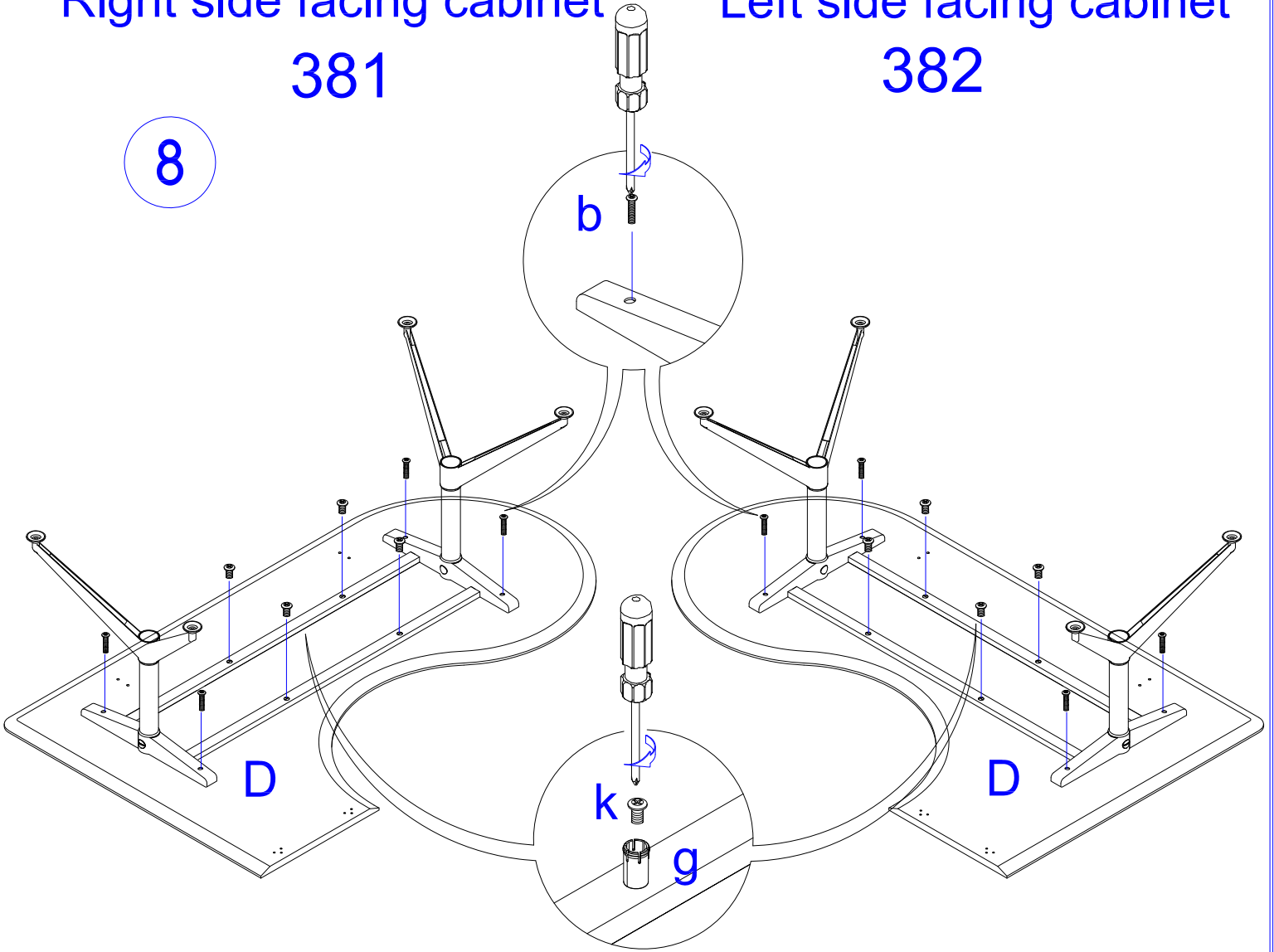

9

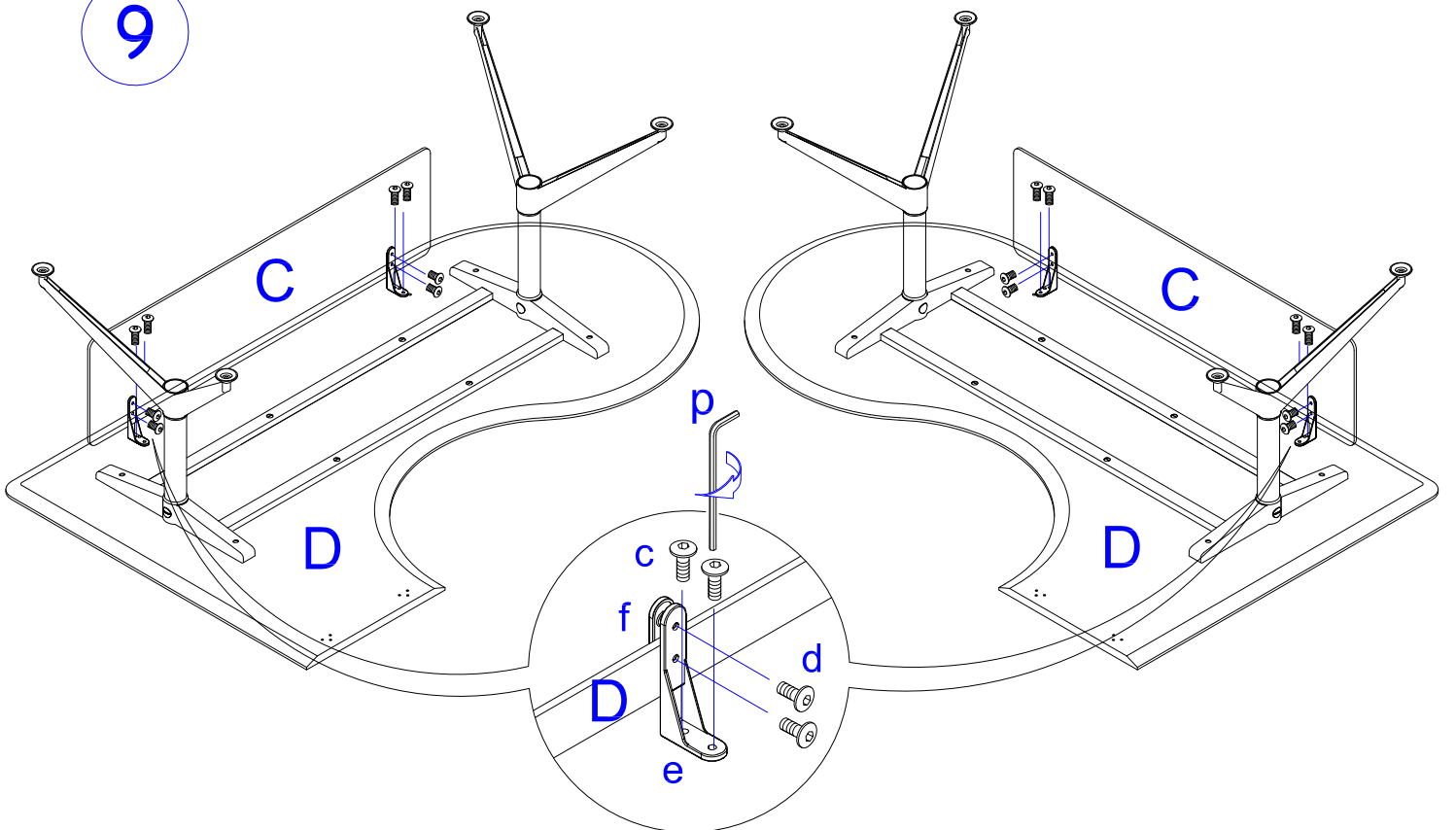

382

10

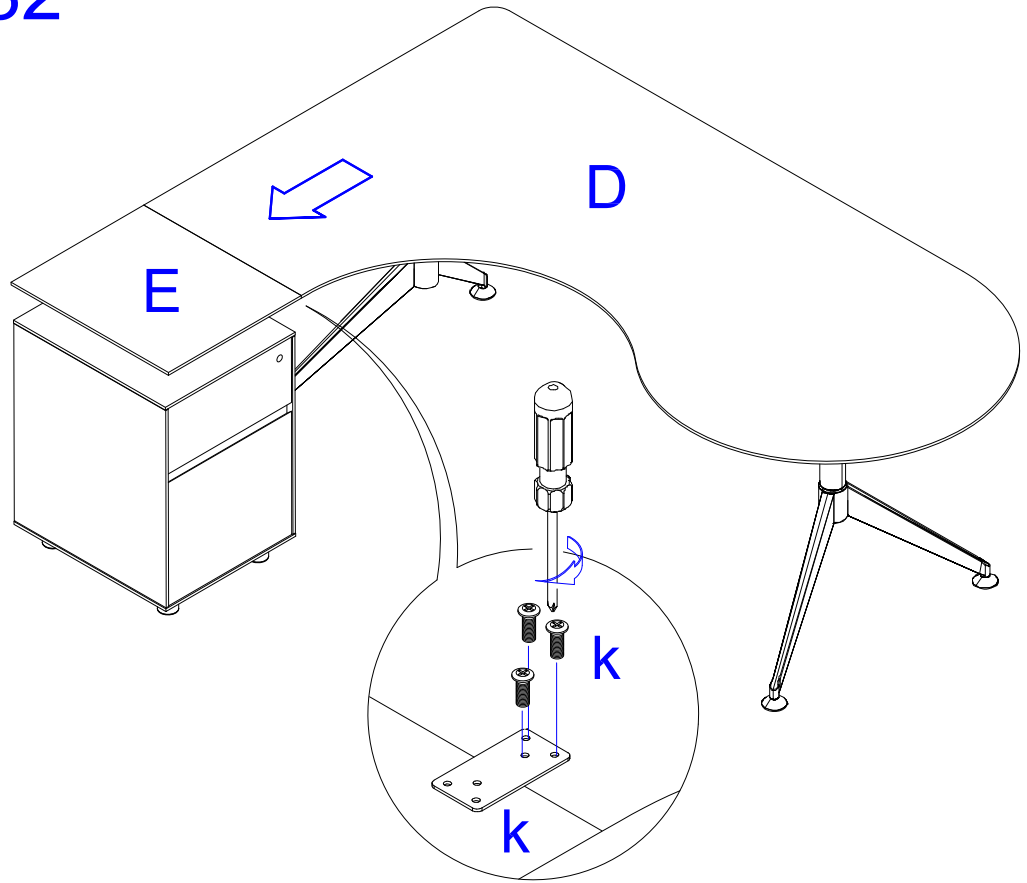

381

10

