

52760280229
52530280229

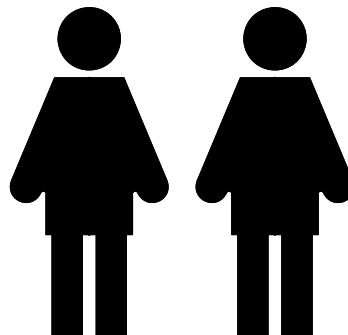
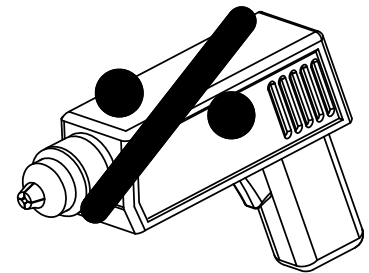
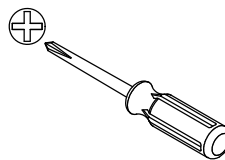
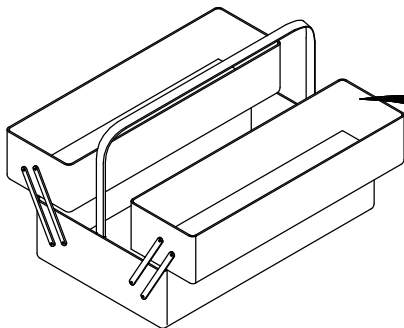
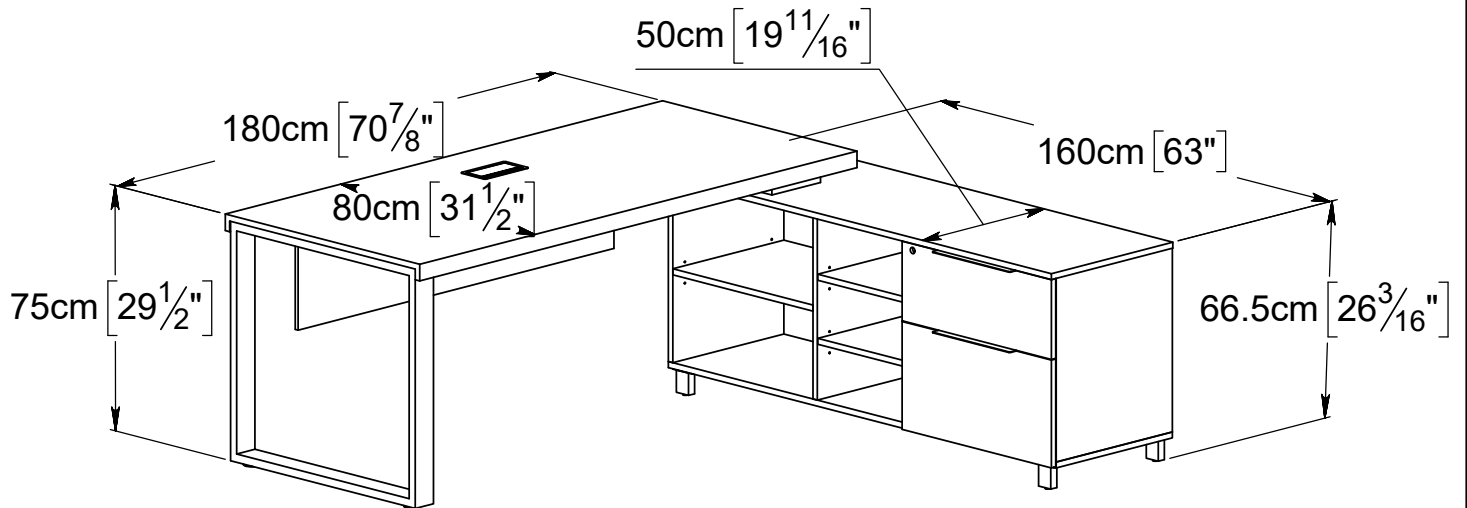

WICHTIG - FÜR SPÄTERE VERWENDUNG
AUFBEWAHREN - SORGFÄLTIG LESEN

AVIS - Ces instructions doivent être sauvegardées
Pour utilisation future - Les instructions doivent
être suivies

IMPORTANTE, conservar estas instrucciones
para futuro uso. Siga estas instrucciones atentamente

VIGTIGT - Samlevejledningen skal opbevares
i arkiv til senere brug - Skal gennemlæses nøje

NOTICE - These instructions must be saved
for future use - Instructions must be followed

TEILCHECKLISTE
 LISTE DE CONTROLE
 LISTADO DE CONTROL
 TJEKLISTE
 CHECK LIST

Réf./No.	Réf./Art.	Qty./Stck./Quantité	Size / Maß / Dimension (mm)	Qty./Stck./Quantité	✓
1	52x0282901	1	1800x800x50		
2	52x0282902	1	1300x350x22		
3	52090282903	1	760x722x75		
4	52x0289904	1	1600x500x595		
5	52x0282905	2	457x366x18		
6	52x0282906	1	573x457x18		
7	52090282907	6	85x45x70		

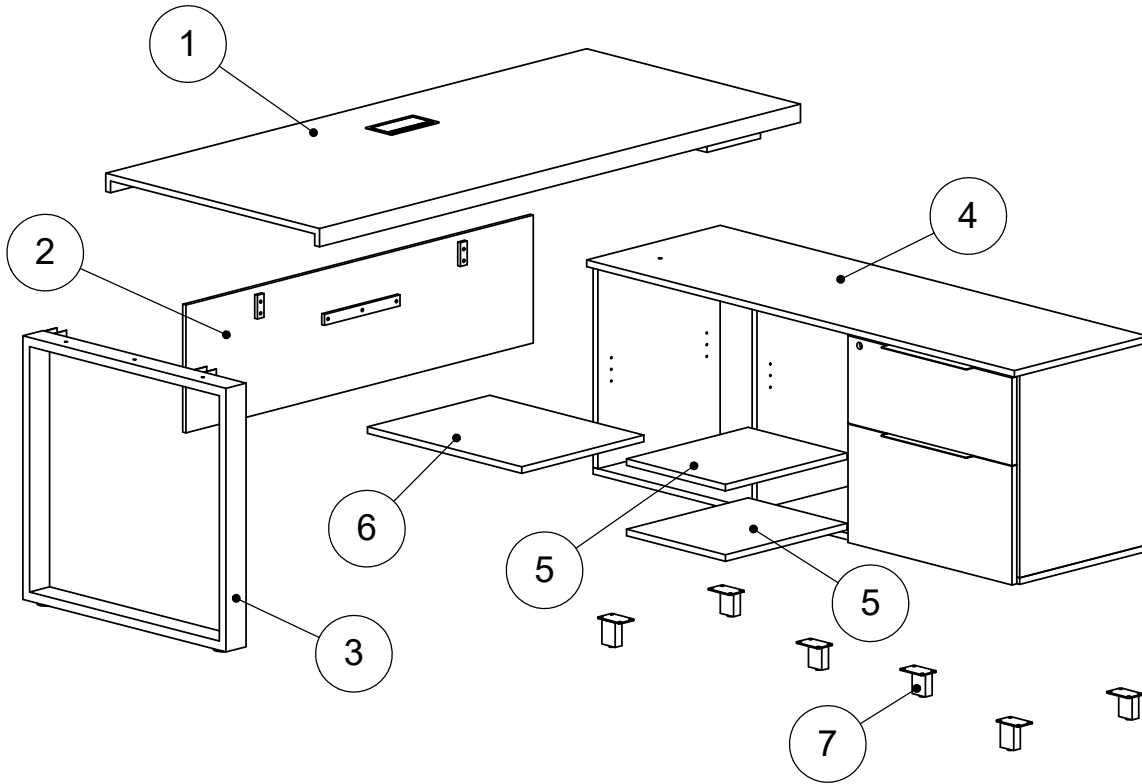

Sollten Sie eventuelle Ersatzteile oder Reklamationsteile fordern, dann bitten wir Sie, diese Seite mitzubringen.

En cas de service apres - vente, veuillez nous retourner ce coupon.

En caso de necesitar piezas de repuesto, por favor adjunte esta página.

Skulle de få brug for reklamationsdele, beder vi dem medsende denne side.

If you should be in the need of spareparts, please enclose this page.

Name/Nom/Nombre/Navn: _____

Adresse/Dirección/Address: _____

PLZ/Code postale/CP/Post.nr: _____

Telefon/Telephone/Telefono/Phone: _____

Oberfläche/Finition/Tratamiento/Behandling/Treatment: _____

No./Référéncie: _____











Ursache/Motif/Motivo/Årsag/Reason: _____

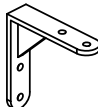

TEILCHECKLISTE - LISTE DE CONTROLE - LISTADO DE CONTROL- TJEKLISTE - CHECK LIST

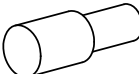
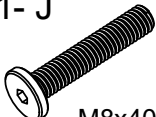
Réf./No.	Réf./Art.	Qty./Stck./Quantité	✓
A	983401	3	
B	983406	19	
C	690003	22	
D	982452	22	
E	690004	1	
F	982432	2	
G	982008	1	
H	981839	12	
J	690011	1	
K	983009	1	
L	983010	1	
M	980924	1	
N	980674	24	

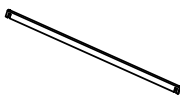
Réf./No.	Réf./Art.	Qty./Stck./Quantité	✓

3 - A  M6x40mm (M6 x 1 9/16")	19 - B  M6x15mm (M6 x 9/16")	22 - C  M6	22 - D  M6	1 - E  4mm (3/16")	2 - F 
1 - G 	12- H 	1- J  M8x40mm (M8 x 1 9/16")	1- K  M8	1- L  M8	1- M 
24 - N  M4x15mm (M4 x 9/16")					

Geehrter Kunde.
Hier haben Sie die Möglichkeit die mitgelieferten Schrauben nachzumessen.

Cher Client.
La règle ci jointe vous permet de mesurer la visserie.

Estimado cliente.
aquí podrá medir la tornillería adjunta.

Kære kunde.
Her har De muligheden for at måle medsendte beslag.

Dear Customer.
Below you have the opportunity to measure the Enclosed Hardware.

Name/Nom/Nombre/Navn: _____

Adresse/Dirección/Address: _____

PLZ/Code postale/CP/Post.nr: _____

Telefon/Telephone/Telefono/Phone: _____

Oberfläche/Finition/Tratamiento/
Behandling/Treatment: _____

No./Référence: _____

Ursache/Motif/Motivo/Årsag/Reason: _____

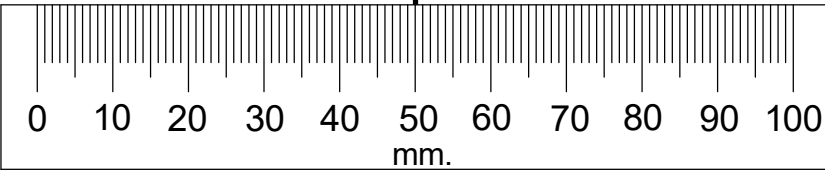

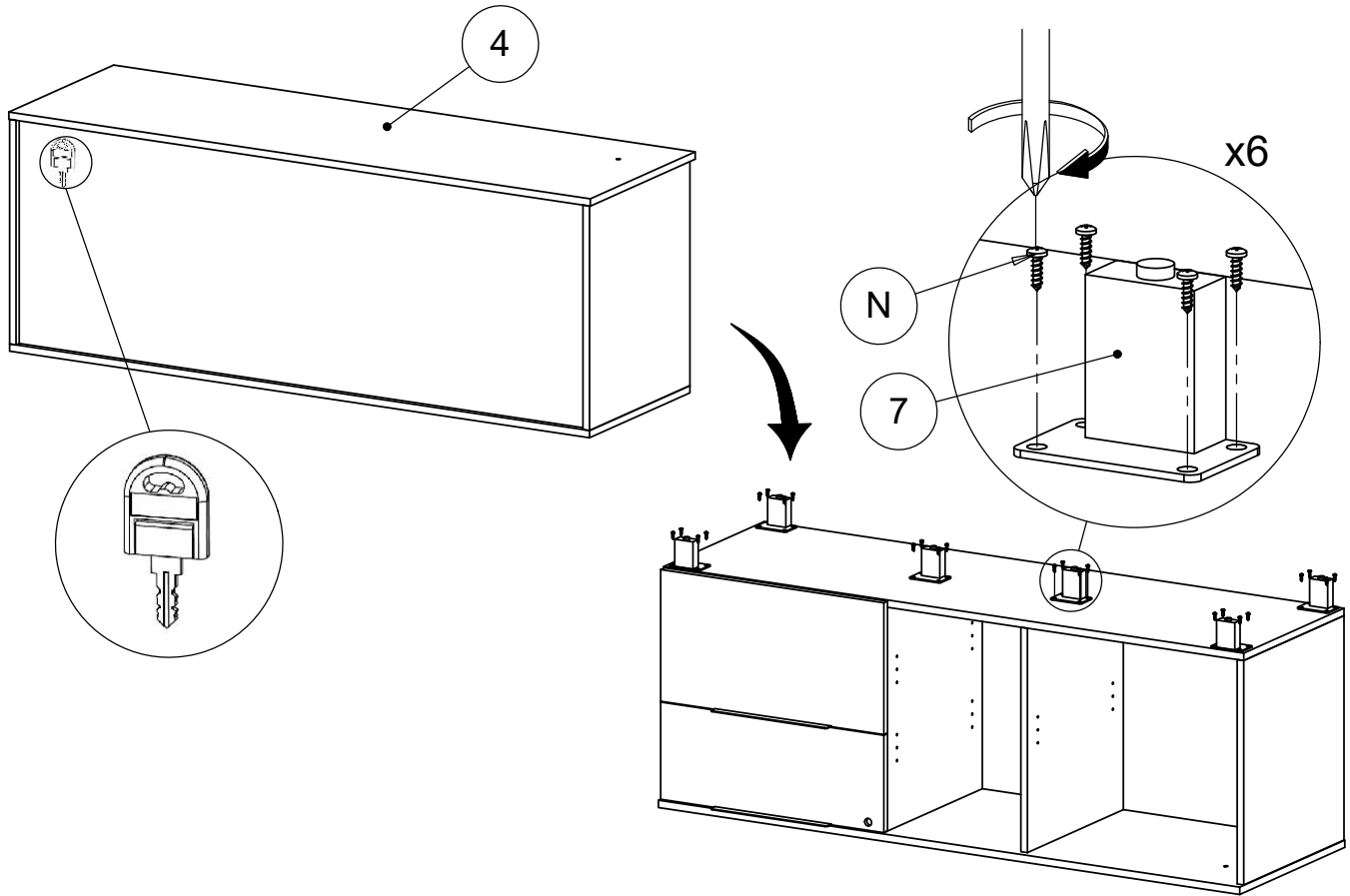

1 24 - N 

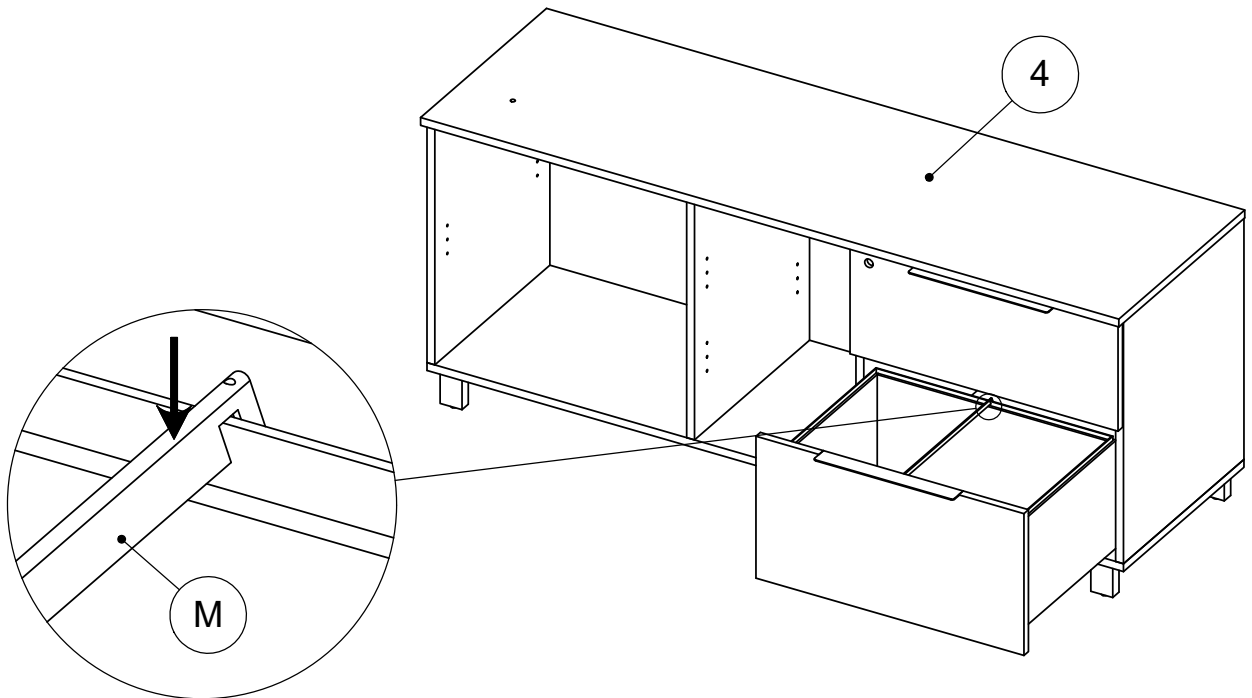

2 1 - M 

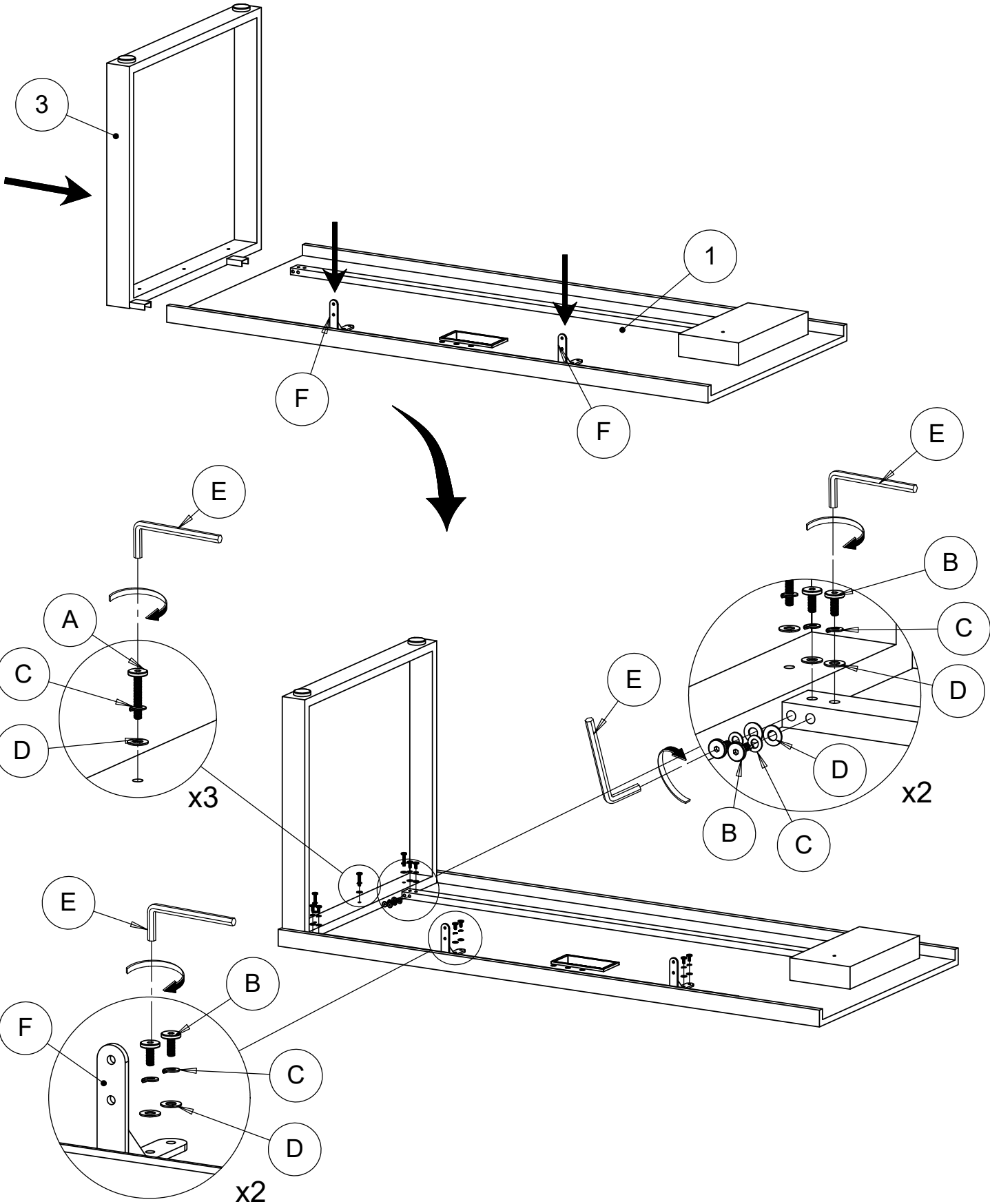
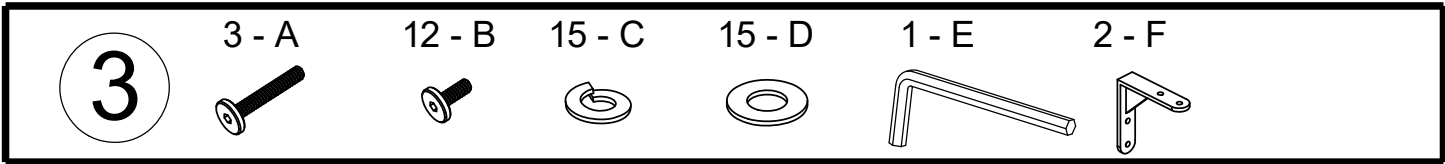



4 4 - B 4 - C 4 - D 1 - E

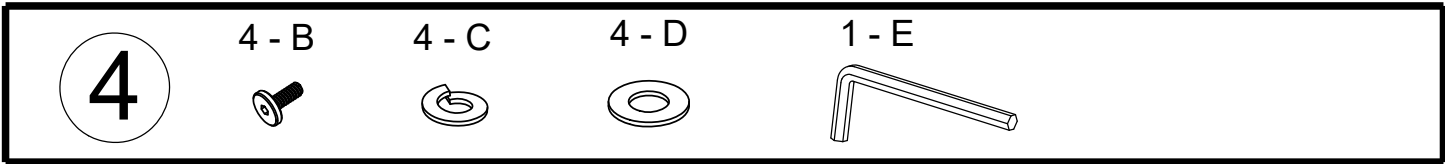
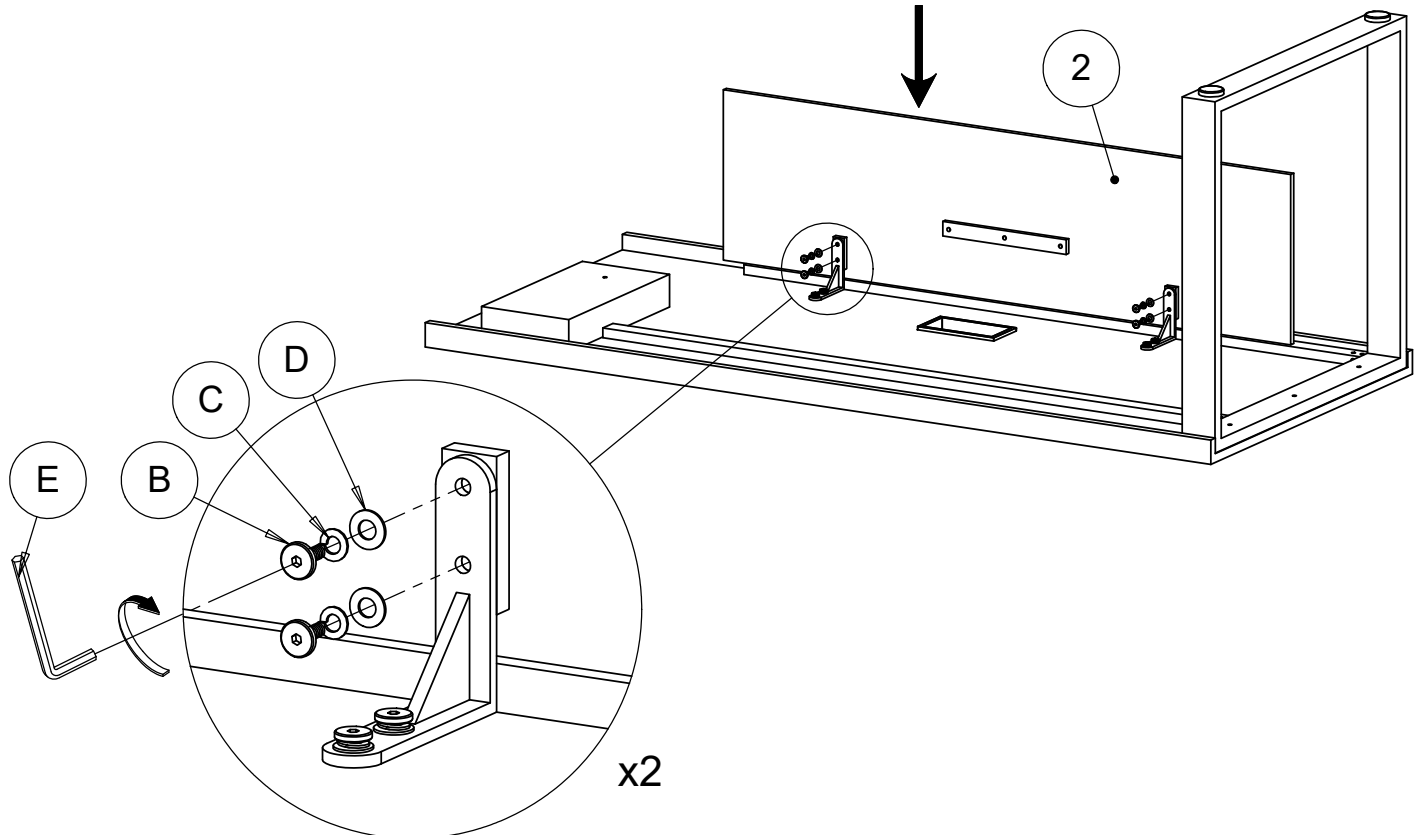

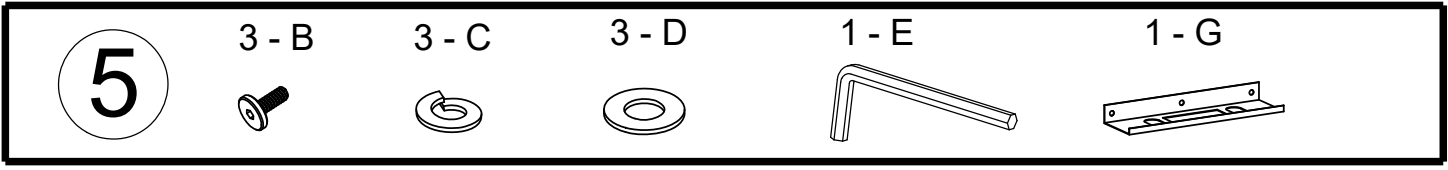
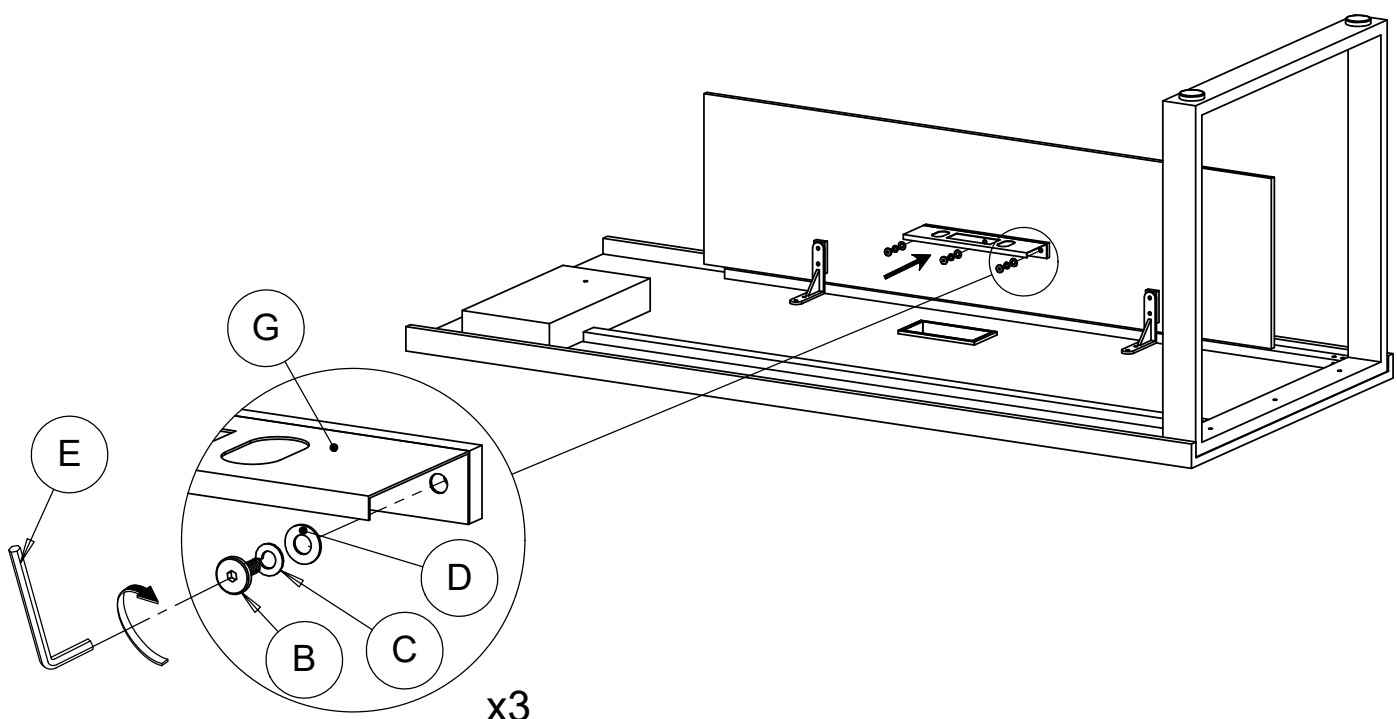

5 3 - B 3 - C 3 - D 1 - E 1 - G

6 12 - H

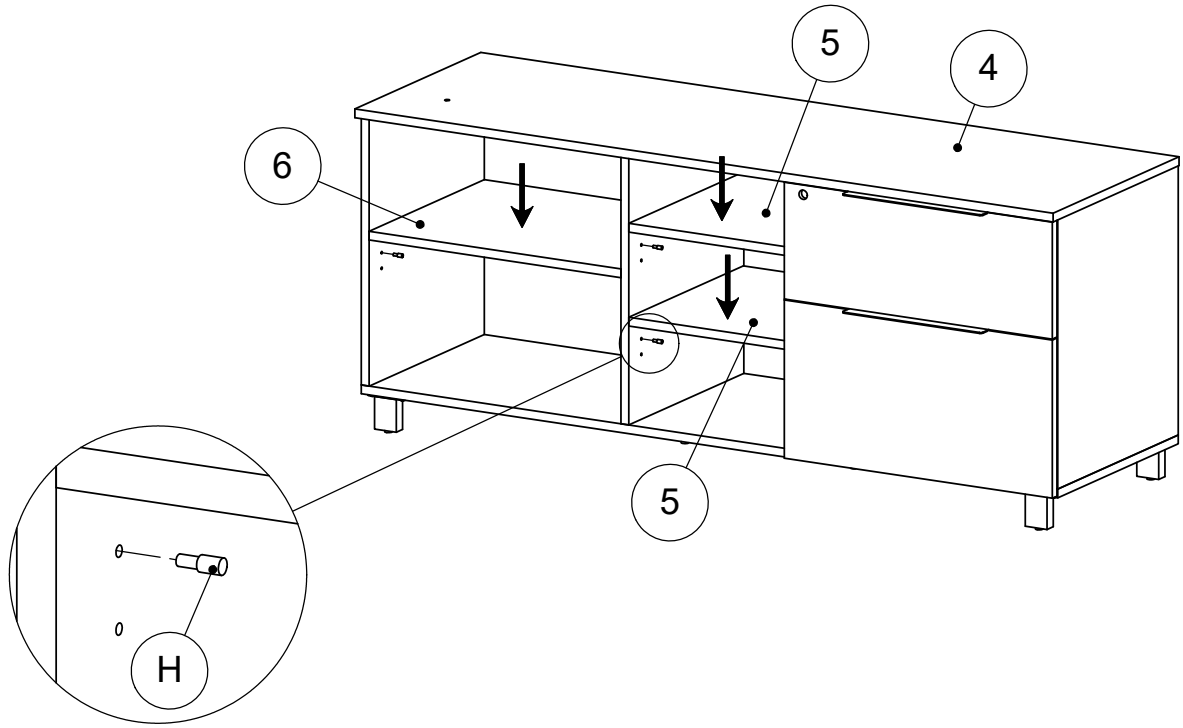
7 1 - J 1 - K 1 - L 1 - E

8

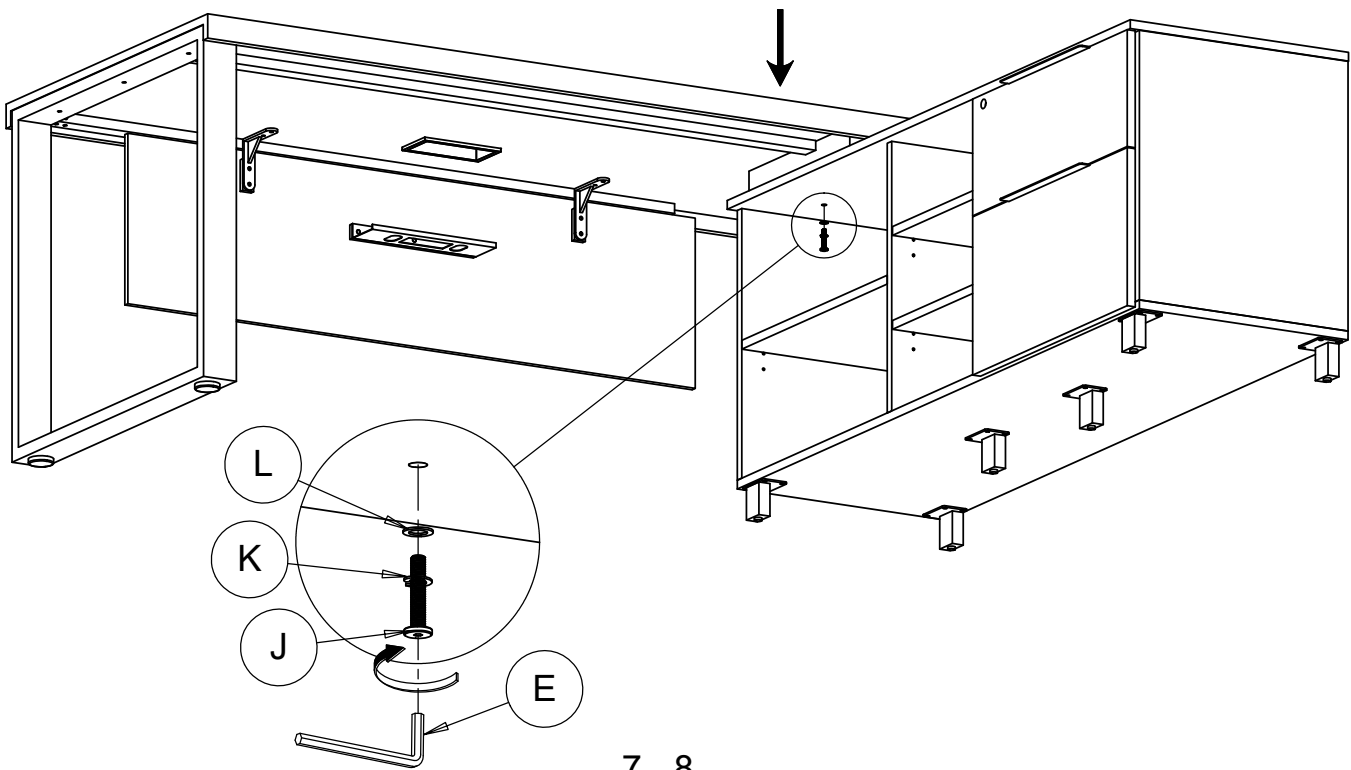